

Modulmat 300 Classic

The Modulmat Classic 300 is a semi-automatic marking system used for medium to high volumes.

The system consists of:

- * An EU Classic power unit (300, 500, 1000)
- * Adjustable Pneumatic piston
- * Stencil positioning fixture
- * Product jiggging blocks
- * 250ml electrolyte reservoir and inbuilt pump

The system operates by the activation of a footswitch, which activates the pneumatic piston - pressing it down onto the stencil onto the product.

The marking cycle is automatically completed with the preset marking settings, piston pressure and electrolyte feed to the marking head.

In this system, the electrolyte is "trickle fed" to the marking head, ensuring it is kept moist.

Various adapters, jiggings and other fixtures can be added to the system to suit various product dimensions or multiple product marking.

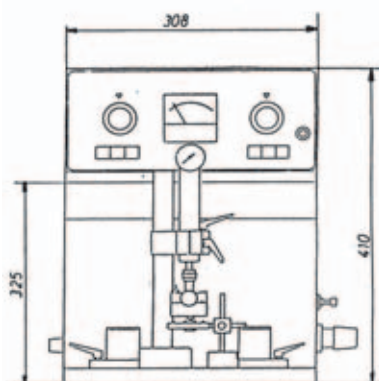
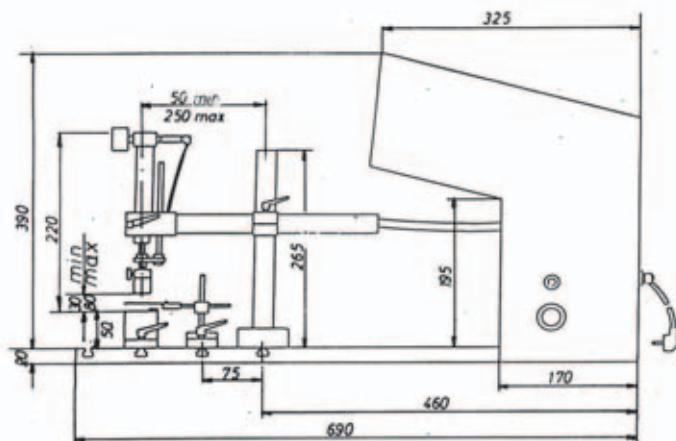
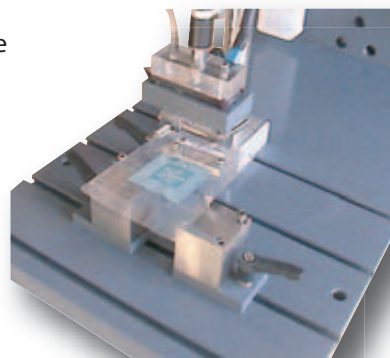
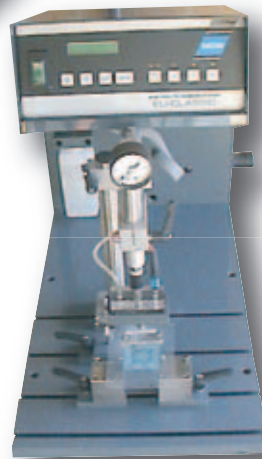

Trend Marking Systems

POSTAL: PO Box 1311 Castle Hill NSW 2154
TEL: 61-2-96299535 FAX: 61-2-96297535
EMAIL: trend@trendmarking.com.au
www.trendmarking.com.au

