

Welcome to the Trend Marking Systems technical pages. The purpose of this page is to provide technical assistance on the installation and maintenance of the Genesis Inkjet Systems.

This site is divided into the following sections:

1. [Genesis Installation](#)
2. [Genesis Maintenance \(including startup procedure\)](#)
3. General tips, tricks and hints



* More will be added to this guide in the future. In the interim please consult your manual or [contact Guido Scholtz at Trend.](#)

Before you install your Genesis SingleLine or TwinLine unit, please check that the following criteria are met. Should you have a concern on any item below, you should contact Trend.

INSTALLATION CHECKLIST

- The printer should be mounted in a location that provides easy access to the printhead for start-up and maintenance procedures.
- The product is to be well guided to ensure a consistent distance from the printhead to the product of maximum 5 mm,- ideally 1-3mm. Applies to radius of curved products also
- The product should not have a moisture or condensation film. An air knife may be required
- The line speed can be up to 76 metres/min and should be consistent.
- The environment should be reasonably stable, ie; no extreme temperature or excessive humidity, no high wind currents.
- Air quality in the printing area to be without excessive dust, powder or other particles
- Excessive vibration through the conveyor to the printer should be avoided (the optional floorstand might be required)
- To avoid smudging after printing there should be no direct contact on the printed area until dry. This can vary according to substrate and ink type.

INSTALLATION DIAGRAMS		
Printhead angled for bottle necks	Printhead side-on	Printhead printing from top down

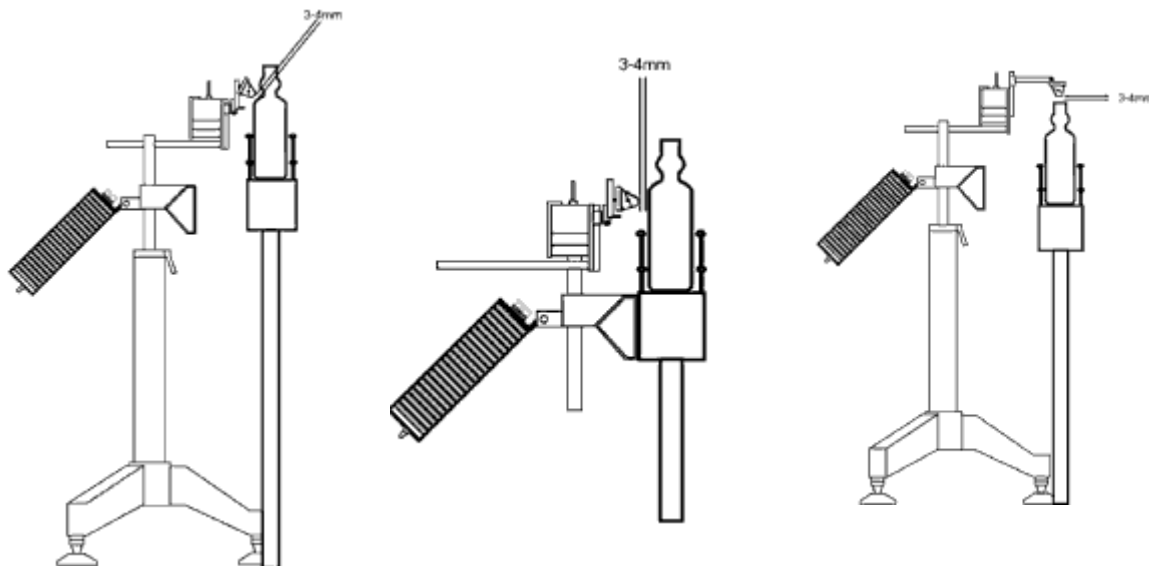

Once the installation checklist above is complete, you are ready to start setting up the unit.

STEP 1: Flush the system with solvent.

Connect a small section of ink-line to the syringe. Fill the syringe with solvent, then attach the solvent filter and another small section of ink-line. Please always fill the syringe with solvent without the filter and attach the filter afterwards.

We will now flush the ink delivery system and clean it of any debris, as well as ensuring the "array plate" (the small metal plate on the printhead) is aiming the dots in the right direction. The unit should at this stage be flushed from the barb on the ink cartridge holder, although during operation, this is done directly from the printhead, so as to not remove the ink cartridge.

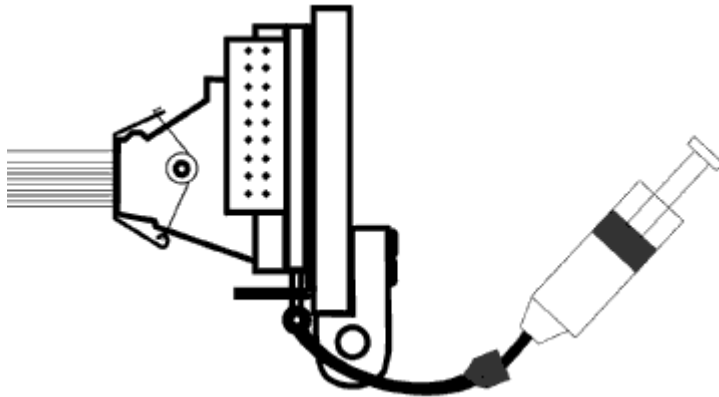

GOOD

Streams exit straight and level.

Note: the gap between the top (vent) stream and the bottom streams is normal (corresponds to the array plate holes) If the top (vent) stream is not straight, the array plate is still usable. Streams need to exit straight and level only within the printing area (ie; within about 5mm of the array plate). After a short distance they will drop off due to gravity.

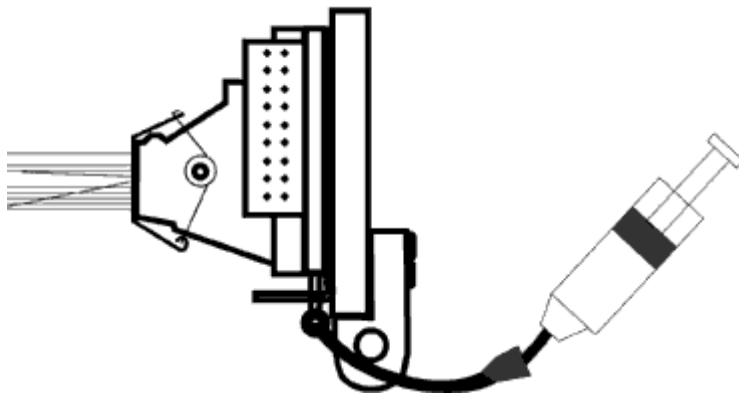

BAD

This array plate needs further cleaning and re-testing as the streams do not exit straight.

Once the system has been flushed and the array plate is good, remove the solvent from the syringe, fill the syringe with air and flush the system again with air, to expel any remaining solvent from the printhead before introducing any ink.

STEP 2: Set your printhead - ink height.

The Genesis ink is fed via capillary action (or "gravity" fed). Therefore the correct height of the printhead in relation to the ink cartridge is critical.

At this stage you will need to use the hand-held controller to set the "AIMS" and "Dot Intensity" values as per the chart below. Please consult your manual on the correct procedure on programming these values.

SIDE CODING New Scale	TEMPERATURES		
INK: 3420BK, 5025BK	40° F (4° C)	72° F (22° C)	100° F (38° C)
Height	-2.5	15	17.5
AIMS	9	7	5
Dot Intensity	8	6	4

BOTTOM CODING New Scale	TEMPERATURES		
INK: 3420BK, 5025BK	40° F (4° C)	72° F (22° C)	100° F (38° C)
Height:	42.5	45	47.5
AIMS	9	7	5
Dot Intensity	9	6	1

BOTTOM CODING New Scale	TEMPERATURES		
INK: 3420BK, 5025BK	40° F (4° C)	72° F (22° C)	100° F (38° C)
Height		5" (13 cm) old scale	5" (13 cm) old scale
AIMS		6	2
Dot Intensity		7	1

Side Coding Head Height

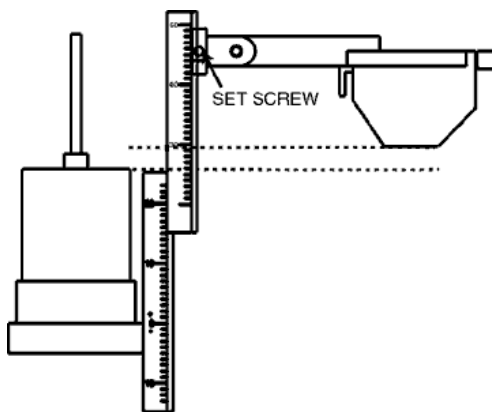

Top Coding Head Height (extension required)

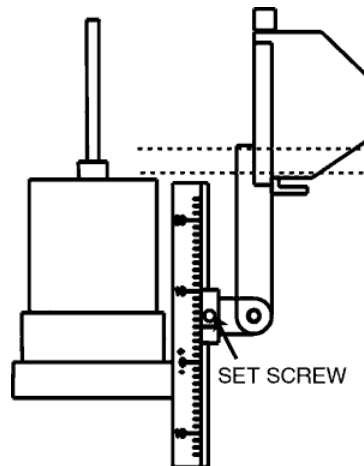

After you have set the required height, you should trim the ink-line so that there is not a large amount of "flex" in the line because this makes the ink-line susceptible to transferred vibration from the conveyor or if the unit is accidentally bumped by the operator.

STEP 3: Insert the ink cartridge and prime the printhead (see below)

To insert the ink cartridge, simply push the cartridge down on the barb and once firmly in place, twist the cartridge a ½ turn. We are now ready to flush the ink through the printhead.

* More will be added to this section in the future. In the interim please consult your manual or [contact Guido Scholtz at Trend.](#)

2. Genesis Startup and maintenance

* More will be added to this section in the future. In the interim please consult your manual or [contact Guido Scholtz at Trend.](#)

Before you follow the procedures below, please ensure that the ink height (especially!) and other parameters for marking are correct. In some cases these procedures should be repeated to get the right result.

STARTUP * Flush with solvent/air first

The light prime is used first when starting up the Genesis units. The procedure is as follows:

1. Light Prime



- With a foam tipped swab or a bunched up cloth/paper towel, press this lightly against the printhead face (the aim is to cover the nozzles)
- Prime lightly to expel some ink onto the cloth and rub the bunched cloth against the printhead (we are using the solvent present in the ink mixture to clean away dried ink or debris)
- Test the print by moving some paper in front of the printhead and press the "cycle" key (or use the photo eye if you are more comfortable). The current message will print.

NOTE: If dots are missing in the print you should lightly prime and rub the array plate again. Repeating this procedure can fix the problem. You might try and prime a little harder each time.

2. Heavy Prime



test print

The heavy prime is used when the light prime does not work. This is not a procedure mentioned by the manufacturer but discovered from customer experience. The risk with using this procedure is that if there is too much pressure exerted on the priming rod, the bag inside may burst, although this is not a common experience. Use the following with some caution.

- Hold a bunched up cloth/paper towel lightly against the printhead face (the aim is to cover the nozzles).
- Prime quite firmly to expel some ink onto the cloth then rub the cloth against the nozzles
- Test the print by moving some paper in front of the printhead and press the "cycle" key (or use the photo eye if you are more comfortable). The current message will print.

NOTE: If you move the cloth approximately 5mm away from the face of the printhead, it is sometimes possible (especially if the printhead is relatively "fresh" (ie; recently rebuilt) to see the ink expelled in streams (as though you were flushing the system with solvent).

3. Remove array plate

If the above procedures do not work, you will need to remove and refit the array plate

- Remove the holding spring and lift the holding clamp off.
- Remove the array plate (be careful not to bend the plate out of shape - some solvent will help to loosen it off)
- Clean the array plate with some solvent
- Clean the nozzle face with a cut down acid brush
- Lightly prime the system and rub the nozzle face with the cloth
- Replace the array plate (ensure it is the right way up!!!)
- Start again at step 1 (LIGHT PRIME THEN HEAVY PRIME)

NOTE: Be careful with the array plate as scratching it or otherwise damaging it can render it unusable. If re-trying steps 1&2 still do not work skip to step 4 - flushing with solvent

4. Flush with solvent

If you are unable to get a good print by following the prompts above, you will need to check the condition of the array plate to see whether or not it is usable. We establish this by flushing the system with solvent and observing the streams as they exit. You might like to skip this step during production and simply fit a new array plate, ensuring the nozzle face is clean. You can then test the suspect array plate later.

- Clamp off the ink line and remove the ink line from the printhead
- Connect syringe to the printhead and flush ink out **with air**.
- Fill syringe with solvent, then attach filter and connect to print-head.
- Flush solvent through printhead and observe ejected streams.
 - If they are straight and level, the array plate is OK.
 - If not, remove the array plate the array plate, clean it well with an acid brush, clean the nozzle face well and re-fit the plate. A few tries might be necessary to be completely sure the array plate is unusable.
- Once a working array plate is fitted connect syringe to the printhead and flush remaining solvent out **with air**.
- Follow the priming procedure from step 1.

Trend Marking Systems

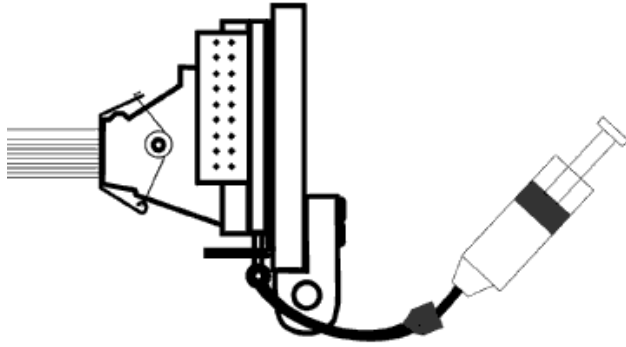

GOOD

Streams exit straight and level. **Note:** the gap between the top (vent) stream and the bottom streams is normal (corresponds to the array plate holes) If the top (vent) stream is not straight, the array plate is still usable. Streams need to exit straight and level only within the printing area (ie; within about 5mm of the array plate). After a short distance they will drop off due to gravity.

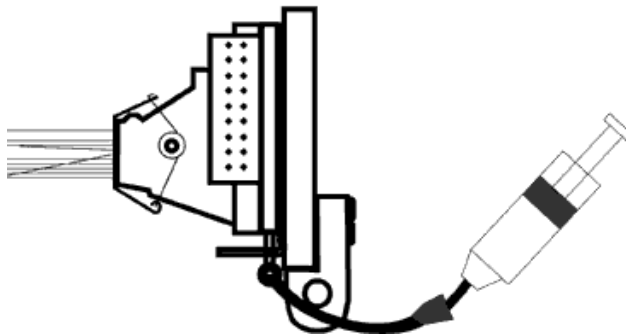

BAD

This array plate needs further cleaning and re-testing as the streams do not exit straight.

Once the system has been flushed and the array plate is good, remove the solvent from the syringe, fill the syringe with air and flush the system again with air, to expel any remaining solvent from the printhead before introducing any ink.

NOTE: Feel free to send suspect array plates to Trend for checking if you are unsure.

- Ensure that the filter is attached only after the solvent is in the syringe.
- Always only use the recommended solvent.
- Be careful with the array plate as scratching it or otherwise damaging it can render it unusable.
- When removing the ink line, there is a special plug underneath the base of the ink-cartridge holder. Connect the ink-line to this plug to reduce ink drying in the ink-line.

SHUTDOWN

1. Short (overnight - 1 week)
2. Long (+1 week)

- Switch the unit off.
- Clean the array plate face with a swab soaked with solvent to remove dried ink.
- Switch the unit off.
- Clamp off the ink line and remove the ink line from the printhead
- Connect syringe to the printhead and flush ink out **with air**.
- Fill syringe with solvent, then attach filter and connect to printhead.
- Flush solvent through printhead and observe ejected streams.
- Flush solvent through printhead until ejected streams are clear.
- Connect syringe to the printhead and flush remaining solvent out with air.
- Clean the array plate face with a swab soaked with solvent.
- Re-connect ink line to printhead and unclamp.

3. General tips, tricks and hints

>>>this list is not yet complete

Using the purge function to check the print.



This is a useful trick to immediately see whether a missing dot can be made to reappear. Follow the procedure below:

1. Place a blank piece of paper in front of the printhead. As it is difficult to have the paper at exactly the right distance away, the paper can touch the printhead lightly if you bend it slightly.
2. Press the "purge" key, the printhead will start "buzzing" loudly and ink will be ejected from all nozzles (except the blocked nozzles)
3. Move the paper back and forth and observe the ink as it is ejected onto the paper. In order to fix blocked nozzles, you can either:
 - Gently tap the priming rod
 - Lightly prime and rub the paper against the printhead to clean and blot away the excess ink
 - Heavy prime and catch the ink on the paper.

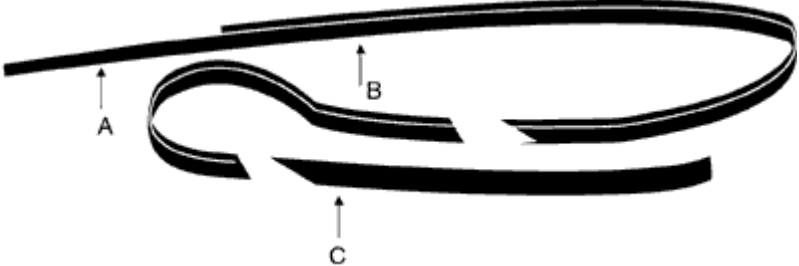

From the above diagram you can see that at point A, the top row is blocked - a light prime and most re-appear except a persistent middle row (point B). A firmer prime has no effect (notice the gap as you prime until the ink is blotted or seeps away) so we re-try and the missing dot re-appears at point C, therefore forming a solid black line.

NOTE: It is sometimes difficult to see whether the top and bottom lines are present.

.....
 T R E N D M A R K I N G S Y S T E M S
 PO Box 1311 Castle Hill NSW 2154 Australia
 PH 61 2 9629 9535 FAX 61 2 9629 7535
www.trendmarking.com.au
