

4 INSTALLATION OF THE HOT QUICKCODER

4.1 Assembly instructions

Figure 7a: options for coding products

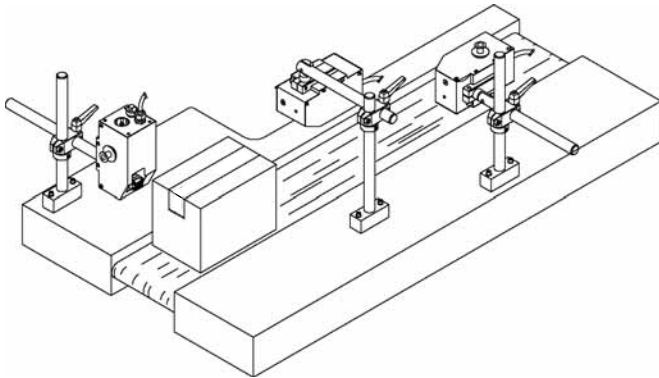
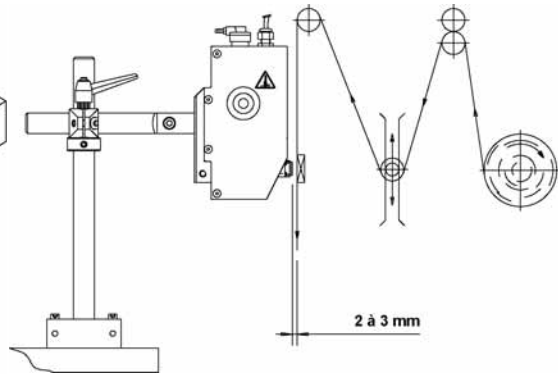

Figure 7b: options for coding lengths of film



See Figure 7 for a summary of the options. During assembly ensure that sufficient space is left around the coder to replace the Hotroll and to change the text head. If necessary, set up the coder so that it revolves. The dimensional sketches are included in Appendix D.

1. Mark the desired position of the holes for assembling the support (pitch is 70 mm). When determining the position, take account of the fact that the text head (in the marked position) should ultimately be located approx. 2-3 mm from the product surface to be printed (figure 7b).
2. Drill the fixing holes for the support (diameter 6.5 mm of M6).
3. Assemble the support with M6 bolts (x2).
4. Fix the coder to the support.
5. Mark the desired position of the holes for assembling the Control box (pitch is 70 mm).
6. Drill the fixing holes for the Control box (diameter 4.5 mm of M4).
7. Assemble the Control box with M4 bolts and/or nuts (x4).



Trend Marking Systems

PO Box 1311 Castle Hill NSW 2154
TEL: 02 96299535 FAX 02 96297535
EMAIL: trend@trendmarking.com.au
www.trendmarking.com.au

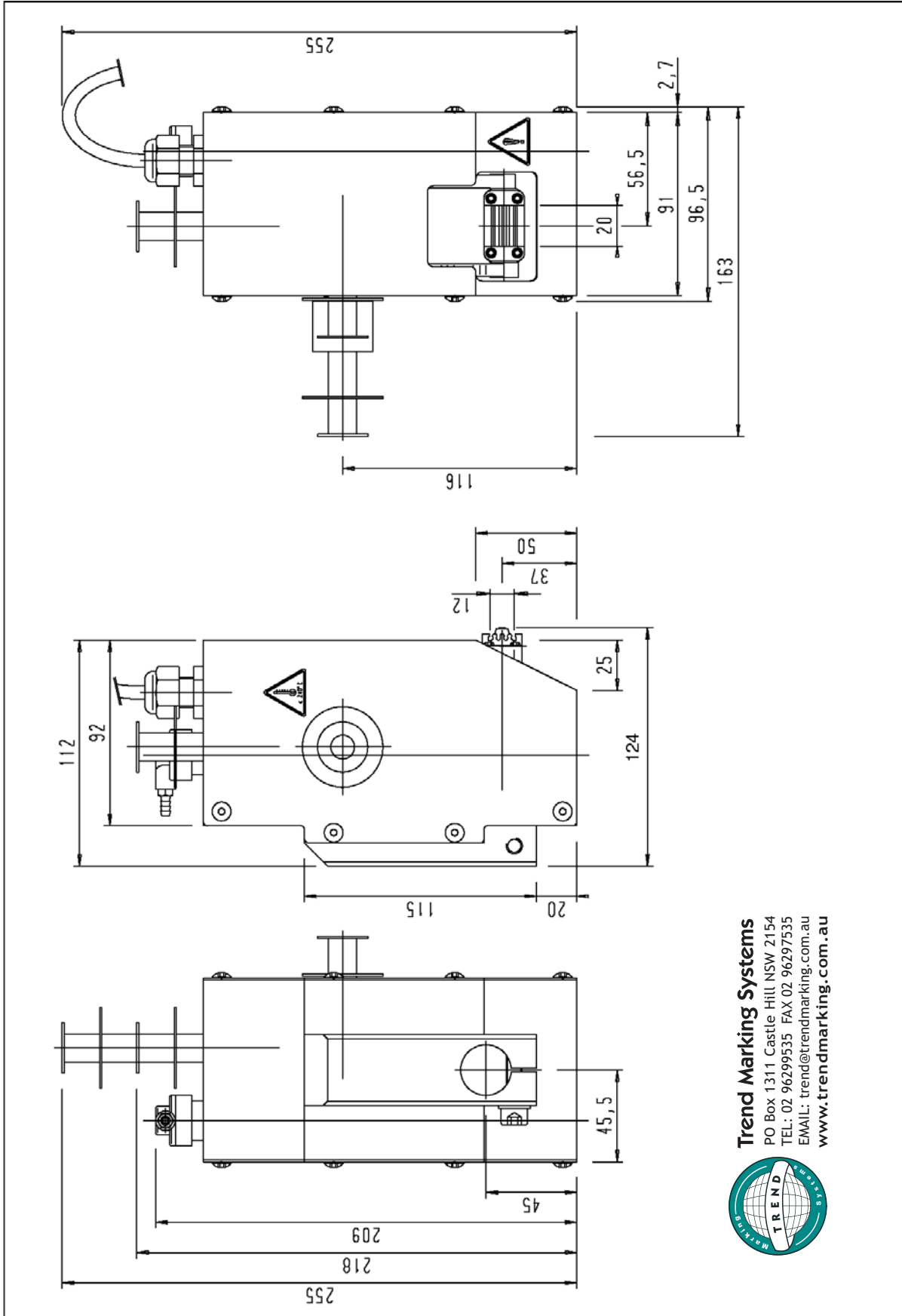

Item number: 810819 Hot Quickcoder

-AT



Trend Marking Systems
 PO Box 1311 Castle Hill NSW 2154
 TEL: 02 96299535 FAX 02 96297535
 EMAIL: trend@trendmarking.com.au
www.trendmarking.com.au

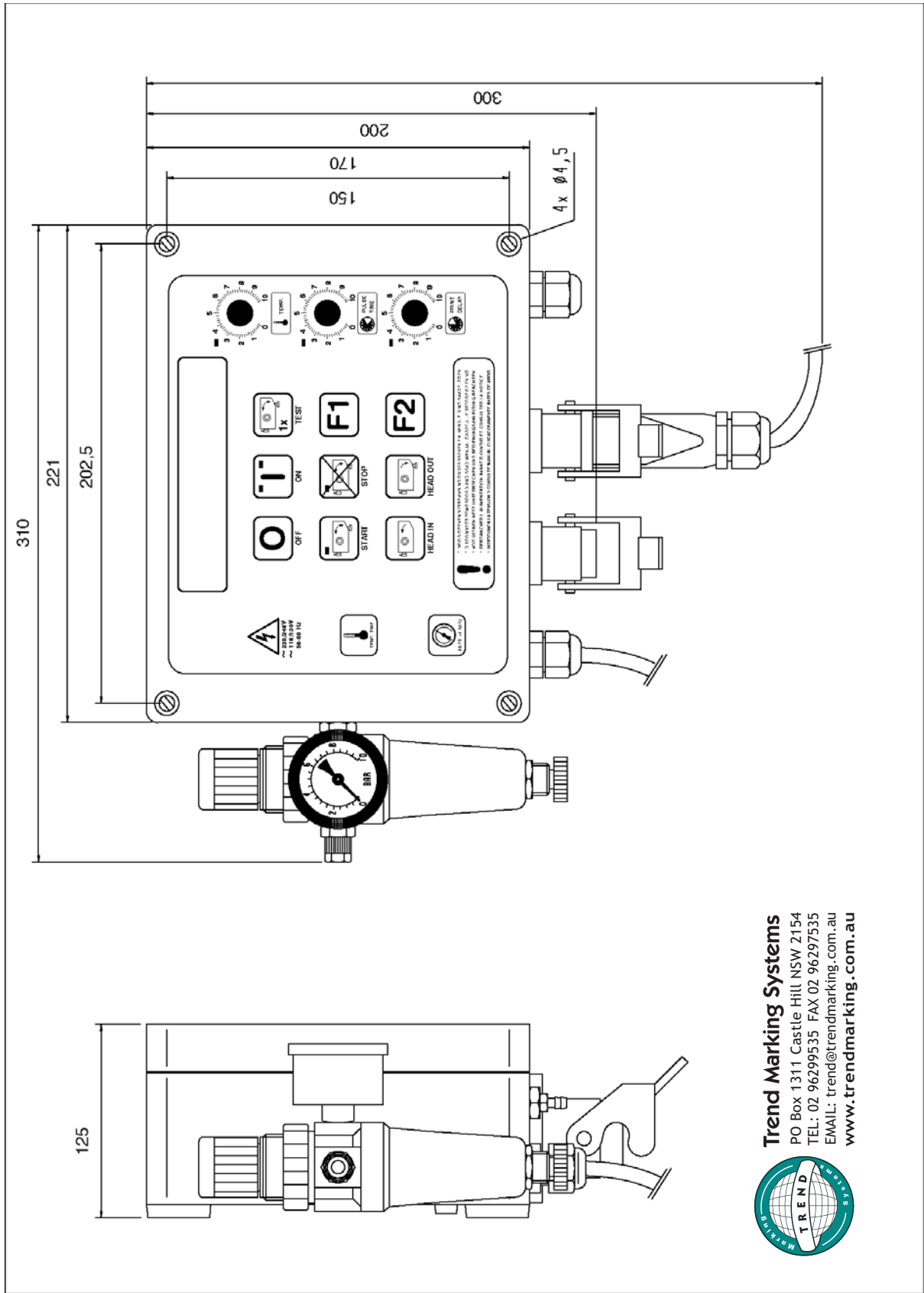

Item number: 810387 Commandokast / Control box HQC

-AT



Trend Marking Systems
 PO Box 1311 Castle Hill NSW 2154
 TEL: 02 96299535 FAX 02 96297535
 EMAIL: trend@trendmarking.com.au
www.trendmarking.com.au

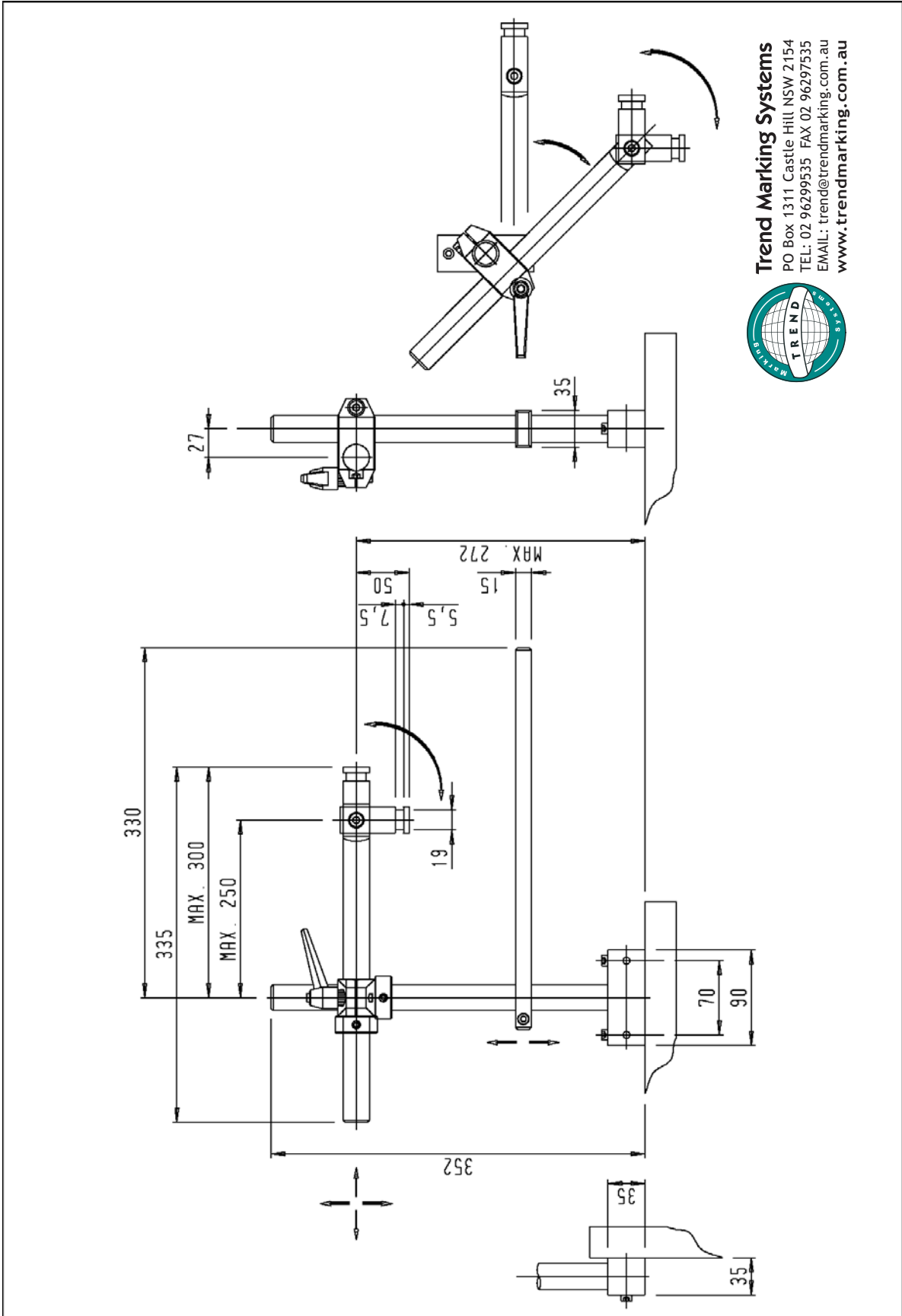

Trend Marking Systems
 PO Box 1311 Castle Hill NSW 2154
 TEL: 02 96299535 FAX 02 96297535
 EMAIL: trend@trendmarking.com.au
 www.trendmarking.com.au



Item number: 809477Standard support HQC